

||||| RADIANCE

MICROWAVE OVEN

TMW-1100ER

OPERATING
INSTRUCTIONS

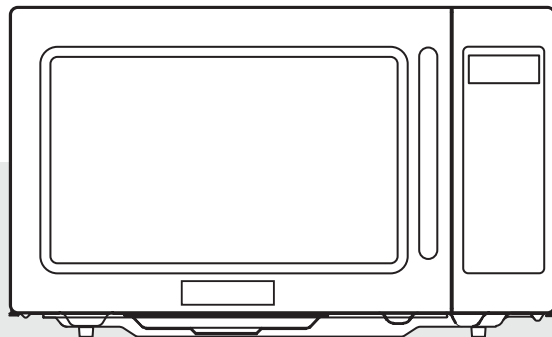

Before operating this oven, please read these instructions completely.

PRECAUTIONS TO AVOID POSSIBLE EXPOSURE TO EXCESSIVE MICROWAVE ENERGY

- (a) **Do not attempt to operate this oven with the door open** since open-door operation can result in harmful exposure to microwave energy. It is important not to defeat or tamper with the safety interlocks.
- (b) **Do not place any object** between the oven front face and the door or allow soil or cleaner residue to accumulate on sealing surfaces.
- (c) **Do not operate the oven if it is damaged.** It is particularly important that the oven door close properly and that there is no damage to the: (1) door (bent), (2) hinges and latches (broken or loosened), (3) door seals and sealing surfaces.
- (d) The oven should not be adjusted or repaired by anyone except properly qualified service personnel.

TABLE OF CONTENTS

PRECAUTIONS TO AVOID POSSIBLE EXPOSURE TO EXCESSIVE MICROWAVE ENERGY	1
TABLE OF CONTENTS	1
IMPORTANT SAFETY INSTRUCTION.....	2
RADIO FREQUENCY INTERFERENCE STATEMENT	
FEDERAL COMMUNICATIONS COMMISSION (U.S.A ONLY)	3
GROUNDING INSTRUCTIONS	3
INSTALLATION.....	4
SPECIFICATIONS	5
FEATURES DIAGRAM	6
OPERATION PROCEDURE	8
CONTROLS	9
TIME DEFROSTING.....	9
COOKING IN ONE STAGE	9
MEMORY FUNCTION	10
START +/-30 SEC	11
CHECK FUNCTION.....	11
DOUBLE QUANTITY FUNCTION	11
CHILD SAFETY LOCK	12
POWER SAVE MODE.....	12
MUTE FUNCTION	12
TO STOP THE OVEN WHILE THE OVEN IS OPERATING	12
ABNORMAL MESSAGE.....	12
MICROWAVING PRINCIPLES	13
HOW MICROWAVES COOK FOOD.....	13
CONVERSION CHARTS	13
COOKING INSTRUCTIONS	14
COOKING TECHNIQUES.....	15
DEFROSTING GUIDE	16
COOKING & REHEATING CHART.....	17
VEGETABLE CHART.....	19
CARE OF YOUR MICROWAVE OVEN	20
CARE AND CLEANING	20
USE YOUR MICROWAVE OVEN SAFELY	21
ARCING	21
BEFORE YOU CALL FOR SERVICE	22
QUESTIONS AND ANSWERS	23

IMPORTANT SAFETY INSTRUCTIONS

When using electrical appliances, basic safety precautions should be followed, including the following:

WARNING - To reduce the risk of burns, electric shock, fire, injury to persons or exposure to excessive microwave energy:

1. Read all instructions before using the appliance.
2. Read and follow the specific "PRECAUTIONS TO AVOID POSSIBLE EXPOSURE TO EXCESSIVE MICROWAVE ENERGY" found on page 1.
3. This appliance must be grounded. Connect only to properly grounded outlet.
See "GROUNDING INSTRUCTIONS" found on page 3.
4. Install or locate this appliance only in accordance with the provided installation instructions.
5. Some products such as whole eggs and sealed containers - for example, closed glass jars-are able to explode and should not be heated in this oven.
6. Use this appliance only for its intended use as described in this manual. Do not use corrosive chemicals or vapors in this appliance. This type of oven is specifically designed to heat, cook, or dry food. It is not designed for industrial or laboratory use.
7. As with any appliance, close supervision is necessary when used by children.
8. Do not operate this appliance if it has a damaged cord or plug, if it is not working properly, or if it has been damaged or dropped.
9. This appliance should be serviced only by qualified service personnel.
Contact nearest authorized service facility for examination, repair or adjustment.
10. Do not cover or block any openings on the appliance.
11. Do not store this appliance outdoors. Do not use this product near water — for example, near a kitchen sink, in a wet basement, or near a swimming pool, or similar locations.
12. Do not immerse cord or plug in water.
13. Keep cord away from heated surfaces.
14. Do not let cord hang over edge of table or counter.
15. When cleaning surfaces of door and oven that comes together on closing the door, use only mild, non-abrasive soaps or detergents applied with a sponge or soft cloth.
16. To reduce the risk of fire in the oven cavity:
 - a) Do not overcook food. Carefully attend appliance when paper, plastic, or other combustible materials are placed inside the oven to facilitate cooking.
 - b) Remove wire twist ties from paper or plastic bags before placing bag in oven.
 - c) If materials inside the oven ignite, keep oven door closed, turn oven off, and disconnect the power cord, or shut off power at the fuse or circuit breaker panel.
 - d) Do not use the cavity for storage purposes. Do not leave paper products, cooking utensils, or food in the cavity when not in use.
17. Do not use this microwave oven to heat corrosive chemicals (for example, sulfides and chlorides). Vapours from such corrosive chemicals may interact with the contact and springs of the safety interlock switches thereby rendering them inoperable.
18. Keep the waveguide cover clean at all times. Wipe the microwave interior with a soft damp cloth after each use. If you leave grease or fat anywhere in the cavity it may overheat, smoke or even catch fire when next using the microwave.
19. Never heat oil or fat for deep frying as you cannot control the temperature and doing so may lead to overheating and fire.
20. Liquids, such as water, coffee, or tea are able to be overheated beyond the boiling point without appearing to be boiling due to surface tension of the liquid. Visible bubbling or boiling when the container is removed from the microwave oven is not always present. **THIS COULD RESULT IN VERY HOT LIQUIDS SUDDENLY BOILING OVER WHEN A SPOON OR OTHER UTENSIL IS INSERTED INTO THE LIQUID.** To reduce the risk of injury to persons:
 - 1 Do not overheat the liquid.
 - 2 Stir the liquid both before and halfway through heating it
 - 3 Do not use straight-sided containers with narrow necks.
 - 4 After heating, allow the container to stand in the microwave oven for a short time before removing the container.
 - 5 Use extreme care when inserting a spoon or other utensil into the container.

SAVE THESE INSTRUCTIONS

RADIO FREQUENCY INTERFERENCE STATEMENT FEDERAL COMMUNICATIONS COMMISSION (U.S.A ONLY)

WARNING:

This equipment generates and uses ISM frequency energy and if not installed and used properly, that is in strict accordance with the manufacturer's instructions, may cause interference to radio and television reception.

It has been type-tested and found to comply with limits for an ISM Equipment pursuant to part 18 of FCC Rules, which are designed to provide reasonable protection against such interference in a residential installation.

However, there is no guarantee that interference will not occur in a particular installation.

If this equipment does cause interference to radio or television reception, which can be determined by turning the equipment off and on, the user is encouraged to try to correct the interference by one or more of the followings.

- Reorient the receiving antenna of radio or television.
- Relocate the Microwave oven with respect to the receiver.
- Move the microwave oven away from the receiver.
- Plug the microwave oven into a different outlet so that microwave oven and receiver are on different branch circuits.

THE MANUFACTURER is not responsible for any radio or TV interference caused by UNAUTHORIZED MODIFICATION to this microwave oven. It is the responsibility of the user to correct such interference.

GROUNDING INSTRUCTIONS

This appliance must be grounded. In the event of an electrical short circuit, the grounding plug reduces the risk of electric shock by providing an escape wire for electric current. This appliance is equipped with a cord having a grounding wire with a grounding plug. The plug must be plugged into an outlet that is properly installed and grounded.

WARNING:

Improper use of the grounding can result in a risk of electric shock.

Consult a qualified electrician or serviceman if the grounding instructions are not completely understood, or if doubt exists as to whether the appliance is properly grounded.

- If it is necessary to use an extension cord, use only a 3-wire extension cord that has a 3-blade grounding plug, and a 3-slot receptacle that will accept the plug on the appliance.

The marked rating of the extension cord shall be equal to or greater than the electrical rating of the appliance.

WARNING:

Do not cut or remove the third (ground) prong from the power cord under any circumstances.

INSTALLATION

- 1 Examine the oven after unpacking.**
Check for damage such as a misaligned door, broken door or dent in the cavity.
If any damage is visible, DO NOT INSTALL, and notify your dealer immediately.
- 2 Level, flat location.**
Install the microwave oven on a level, flat surface.
- 3 Ventilation.**
Do not block air vents. If they are blocked during operation, the oven may overheat and eventually cause a failure. For proper ventilation, allow 4 inches of space between oven top, sides, rear and adjacent surfaces.
- 4 Away from radio and TV sets.**
Poor television reception and radio interference may result if the oven is located close to a TV, radio, antenna, feeder, etc. Place the oven as far from them as possible.
- 5 Away from heating appliances and water taps.**
Keep the oven away from heat, steam or splashing liquids. These things can adversely affect oven wiring and contacts.

- 6 Power supply.**
 - Check your local power source.
This microwave oven requires a current of approximately 14.5 amperes, 120Volts, 60Hz grounded outlet.
 - 1. A short power-supply cord is provided to reduce the risks resulting from becoming entangled in or tripping over a longer cord.
 - 2. Longer cord sets or extension cords are available and may be used if care is exercised in their use.
 - 3. If a long cord or extension cord is used:
 - The marked electrical rating of the cord set or extension cord should be at least as great as the electrical rating of the appliance.
 - The extension cord must be a grounding type 3-wire cord.
 - The longer cord should be arranged so that it will not drape over the counter top or tabletop where it can be pulled on by children or tripped over unintentionally.
- 7** The minimum height of free space necessary above the top surface of the oven is 4inch.

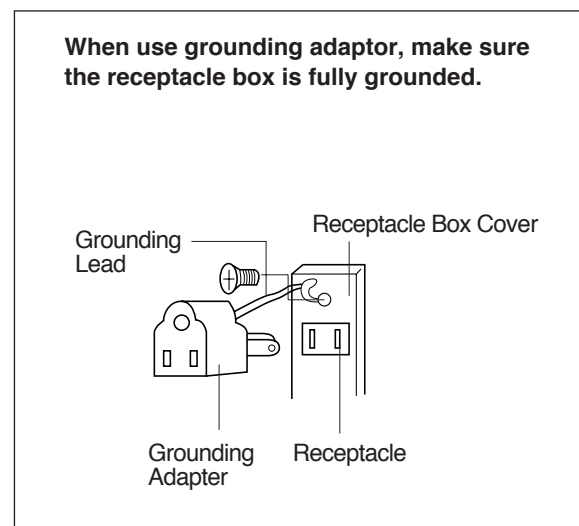
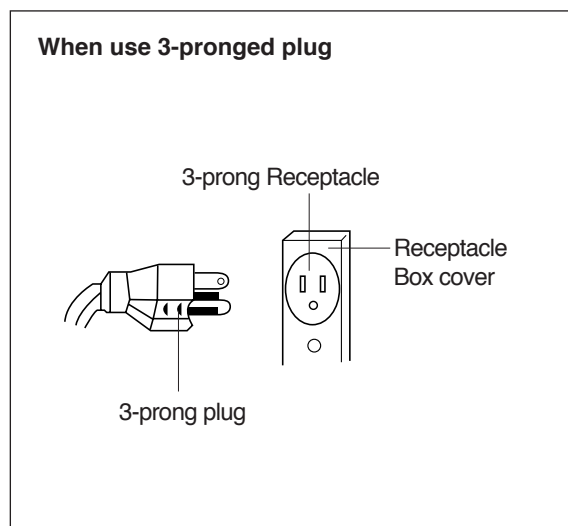

“THE CANADIAN ELECTRICAL CODE DOES NOT ALLOW THE USE OF THE GROUNDING ADAPTOR”

When it takes over 30 seconds for cooking, the cooling fan runs for a few minutes after cooking has stopped.

SPECIFICATIONS

POWER SUPPLY		120V AC 60 Hz SINGLE PHASE WITH GROUNDING
MICROWAVE	POWER CONSUMPTION	1500W
	OUTPUT POWER	1000W
	FREQUENCY	2450 MHz
OUTSIDE DIMENSIONS (W x H x D)		542 x 329 x 461 mm (21.34 x 12.95 x 18.15 in.)
CAVITY DIMENSIONS (W x H x D)		350 x 230 x 357 mm (12.78 x 3.06 x 14.06 in.)
NET WEIGHT		APPROX. 18Kg (39.68 lbs.)
TIMER		60min.
POWER SELECTIONS		5 LEVELS

* Specifications are subject to change without notice.

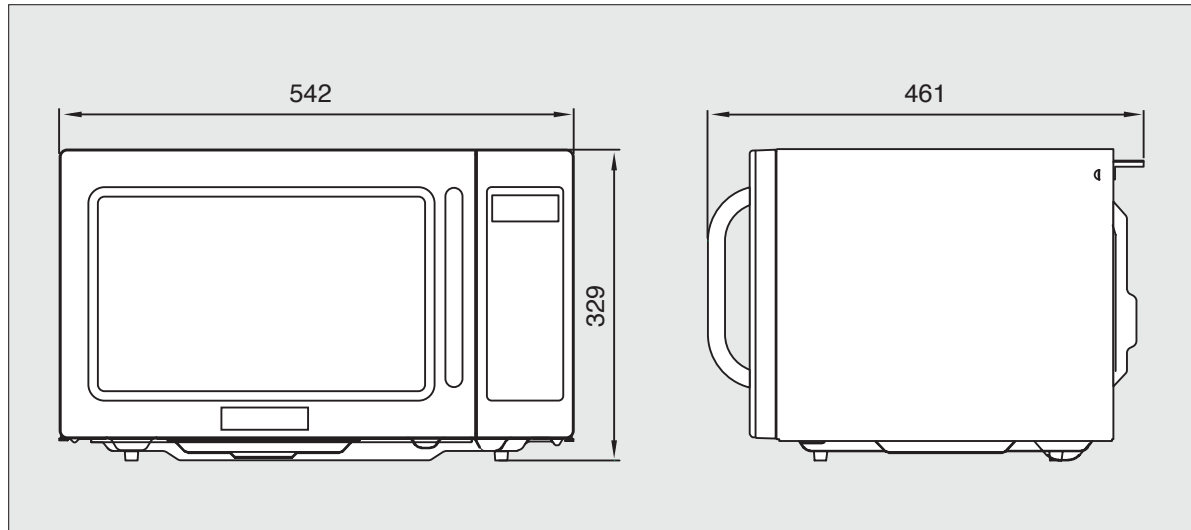

FEATURES DIAGRAM

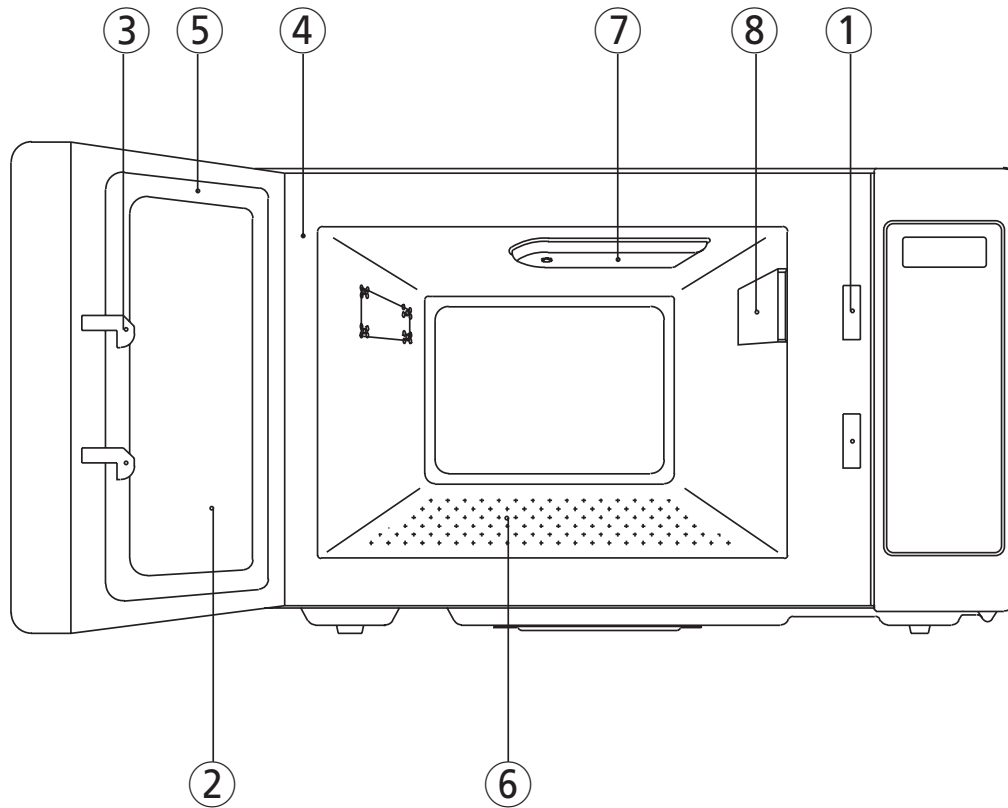

① **SAFETY INTERLOCK SYSTEM.**

② **DOOR VIEWING SCREEN** - Allows viewing of food. The screen is designed so that light can pass through, but not the microwave.

③ **DOOR HOOK** - When door is closed, it will automatically shut off. If the door is opened while the oven is operating, magnetron will immediately stop operating.

④ **OVEN CAVITY.**

⑤ **DOOR SEAL** - Door seal maintains the microwave energy within the oven cavity and prevents microwave leakage.

⑥ **PLATE TRAY** - Made of special heat resistant ceramic. Food in a proper receptacle is placed on this plate for cooking.

⑦ **STIRRER COVER** - This is located on the ceiling with the stirrer fan.

⑧ **INLET COVER** - Protect the air hole from splashes of cooking foods.

FEATURES DIAGRAM (continued)

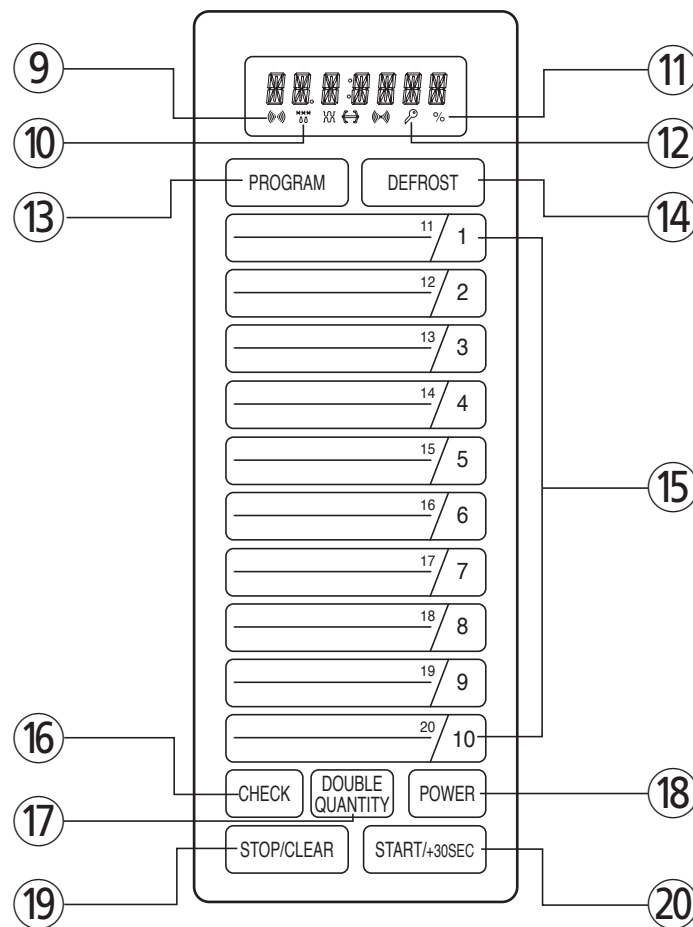

⑨ **MICROWAVE** indicator, showing microwaving in progress.

⑩ **DEFROST** indicator, showing defrosting in progress.

⑪ **PERCENTAGE** of power indicator.

⑫ **CHILD LOCK** indicator.

⑬ **PROGRAM** - Used to save cooking data.

⑭ **DEFROST** - Used to defrost foods for time. (by time)

⑮ **TIME SET PAD** - Used to set the cooking time.

⑯ **CHECK** - Used to check cooking data.

⑰ **DOUBLE QUANTITY** - Used to extend programmed cooking time.

⑱ **POWER** - Used to set power level.

⑲ **STOP/CLEAR** - Used to stop the oven operation or to delete the cooking data.

⑳ **START /+30 SEC** - Used to start the oven and also used to set a reheat time.

OPERATION PROCEDURE

This section includes useful information about oven operation.

1. Plug power supply cord into a standard 3- pronged 15 Amp, 120V AC 60Hz power outlet.
 2. After placing the food in a suitable container, open the oven door and put it on the plate tray.
The plate tray must always be in place during cooking.
 3. Close the door and make sure that it is firmly closed.
- 1 The oven light is on when the microwave oven is operating or the door is opened.
 - 2 The oven door can be opened at any time during operation by opening the door. The oven will automatically shut off.
 - 3 Each time a pad is touched, a BEEP will sound to acknowledge the touch.
 - 4 The oven automatically cooks on full power unless set to a lower power level.
 - 5 The display will show ":0" when the oven is plugged in.
 - 6 When the STOP/CLEAR pad is touched during the oven operation, the oven stops cooking and all information retained.
To erase all information, touch the STOP/CLEAR pad once more. If the oven door is opened during the oven operation, all information is retained.
 - 7 If the START pad is touched and the oven does not operate, check the area between the door and door seal for obstructions and make sure the door is closed securely.
The oven will not start cooking until the door is completely closed or the program has been reset.

Make sure the oven is properly installed and plugged into the electrical outlet.

WATTAGE OUTPUT CHART

- The power-level is set by touching the POWER pad. The chart shows the display, the power level and the percentage of power.

Touch the POWER pad	Power Level (Display)	Approximate Percentage of Power
once	100	100%
twice	80	80%
3 times	60	60%
4 times	40	40%
5 times	20	20%

CONTROLS

TIME DEFROSTING

When DEFROST is selected, the automatic cycle divides the defrosting time into periods of alternating defrost and stand times by cycling on and off.

DEFROST

1. Touch the DEFROST pad. The DEFROST indicator lights and " : 0" is displayed.
2. Touch the number pads for the desired defrosting time. The display will show the numbers you pressed in the order you touched.
3. Touch the START pad.

NOTE: Your oven can be programmed for 60 minutes. (60:00)

When you touch the START pad, the DEFROST indicator lights to show the oven is in the DEFROST mode. The display counts down the time to show you how much defrosting time is left in the DEFROST mode. The oven beeps during the defrosting cycle to signal that the food needs to be turned or rearranged. When the defrosting time ends, you will hear 3 beeps.

COOKING IN ONE STAGE

POWER

x3

1. Touch the POWER pad. (Select desired power level.) The MICROWAVE and % indicators light. The display will show what you touched.
2. Touch the number pads for the cooking time. This example shows power level 60. The display will show the numbers you pressed in the order you touched.
3. Touch the START pad.

NOTE: Your oven can be programmed for 60 minutes. (60:00) but, in case of full power(100%), maximum time is 20 minutes (20:00)

When you touch the START pad, the MICROWAVE indicator lights to show the oven is cooking. The display counts down the time to show how much cooking time is left. When the cooking time ends, you will hear 3 beeps.

NOTE: Using low power levels increases the cooking time which is recommended for foods such as cheese, milk and slow cooking of meats.

NOTE: The cooling fan may operate to prevent the oven being overheated.

MEMORY FUNCTION

This microwave oven has 20 programmable pads (1~20).

PROGRAM

- | | |
|---|---|
| 1. Touch PROGRAM pad. | The display will show "PROGRAM". |
| 2. Touch the NUMBER pad to be programmed.
(ex. number pad 1) | The display will show "PROG-01".
To program pads 11 to 20, touch number pad twice rapidly.
(ex. to program pad 11, touch number pad 1 twice rapidly.) |
| 3. Touch POWER pad.
(Select desired power level.) | The MICROWAVE and % indicators light. |
| 4. Touch the NUMBER pads for cooking time. | The display will show what you touched. |
| 5. Touch START pad to save cooking time and power level. | The display will show "STAGE-2" and long beep sounds. |
| 6. Touch STOP/CLEAR pad. | When you touch STOP/CLEAR pad, MEMORY function ends. |

NOTE 1: If you want cooking in two or three stage, repeat step 3~5 once or twice, and display will show "STAGE-2" or "STAGE-3".
After touching START pad to save cooking time and power level in 3-stage, you can see "- END -" on the display.

NOTE 2: In case of original set, number 1~10 is programmed but cooking data is changeable later.
And number 11~20 is not programmed, so you will save cooking data.

After programming is finished, just touch the NUMBER pad of the memory number you want to select. To select the memory number 11 to 20, touch the number pad twice rapidly. Then the oven will automatically start heating according to the pre-programmed cooking time and power level.

* Preprogrammed Cooking Times and Power Level

Pad	Cooking Time	Power Level
1	10sec.	100 %
2	20sec.	100 %
3	30sec.	100 %
4	45sec.	100 %
5	1 min.	100 %
6	1 min. 30sec.	100 %
7	2 min.	100 %
8	3 min.	100 %
9	4 min.	100 %
10	5 min.	100 %

START /+30 SEC

START /+30 SEC allows you to reheat for 30 seconds at 100% (full power) by simply touching the START /+30 SEC pad.

By repeatedly touching the START /+30 SEC pad, you can also extend reheating time to 5 minutes by 30 second increments.

START /
+30 SEC

1. Touch the START /+30 SEC pad.

When you touch the START /+30 SEC, ":30" is displayed.

The oven will start immediately. It will add 30 seconds to the time counting down each time the pad is touched.

CHECK FUNCTION

This feature allows you to check the programmed cooking time and power level.

CHECK

1. Touch the CHECK pad.
2. Touch the NUMBER pads which you want confirmation.
ex)5

The display will show "CHECK".

The display will show "PROG-05".

The display will show cooking time, power level each stage.
If you want to end, touch the STOP/CLEAR pad.

DOUBLE QUANTITY FUNCTION

This feature allows you to extend programmed cooking time twice temporarily.

But, the extended cooking time can't exceed maximum cooking time.

Maximum cooking time of this oven is 60 minutes except full power.

In case of full power (100%), maximum cooking time is 20 minutes.

DOUBLE
QUANTITY

1. Touch DOUBLE QUANTITY pad.
2. Touch the NUMBER pad.
(ex. number pad 1)

The display will show "DOUBLE".

The display will show "PROG-01".
To select pads 11 to 20, touch number pad twice rapidly.
(ex. to select pad 11, touch number pad 1 twice rapidly.)
After 1.5 seconds, the oven automatically start cooking.

CHILD SAFETY LOCK

The safety lock prevents unwanted oven operation such as by small children.
To set, press and hold the STOP/CLEAR pad for 3 seconds, LOCK indicator lights.
To cancel, press and hold STOP/CLEAR for 3 seconds, LOCK indicator goes off.

POWER SAVE MODE

This function is used for saving energy.
To set, press and hold the CHECK pad for 3 seconds. The oven will beep and nothing appears in the display. Now the oven is in power save mode.
To operate the oven in power save mode, press any pad. Then “ : 0” will shown and the operation of all function key will be same as in normal mode.
But, if there is no operation within 10 seconds in clear mode or while mainpulating the key, all the contents of display will disappear.
To cancel, after press any pad, press and hold the CHECK pad for 3 seconds.
Then the oven is again available for normal use.

MUTE FUNCTION

To set, press and hold the DOUBLE QUANTITY pad for 3 seconds.
The display will show “MUTE” for 1 second.
Then you will not hear beeps, when you press any pad.
To cancel, press and hold the DOUBLE QUANTITY pad for 3 seconds.

TO STOP THE OVEN WHILE THE OVEN IS OPERATING

1. Touch the STOP/CLEAR pad.
 - You can restart the oven by touching START pad.
 - Touch the STOP/CLEAR once more to erase all instructions.
 - You must enter in new instructions.
2. Open the door.
 - You can restart the oven by closing the door and touching the START pad.

NOTE: Oven stops operating when door is opened.

ABNORMAL MESSAGE

E10	<ul style="list-style-type: none"> • “E10” message occurs when the total sum of the stage cooking time is greater than 20 minutes in full power or 60 minutes in other power levels. • Touch the STOP/CLEAR pad and try again.
E20	<ul style="list-style-type: none"> • “E20” message occurs when EEPROM is not able to read cooking data from it’s memory or write cooking data on it’s memory. • Unplug the power and call for service.

MICROWAVING PRINCIPLES

Microwave energy has been used in this country to cook and reheat food since early experiments with RADAR in World War II. Microwaves are present in the atmosphere all the time, both naturally and manmade sources. Manmade sources include radar, radio, television, telecommunication links and car phones.

HOW MICROWAVES COOK FOOD

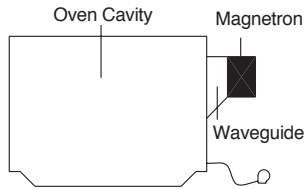

In a microwave oven, electricity is converted into microwave by the **MAGNETRON**.

► TRANSMISSION

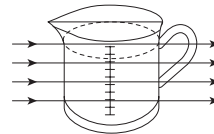

Then they pass through the cooking containers to be absorbed by the water molecules in the food, all foods contain water to a more or lesser extent.

► REFLECTION

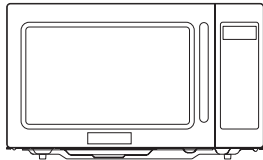

The microwaves bounce off the metal walls and the metal door screen.

► ABSORPTION

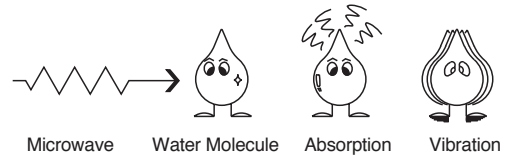

The microwaves cause the water molecules to vibrate which causes **FRICTION**, i.e. **HEAT**. This heat then cooks the food. Microwaves are also attracted to fat and sugar particles, and foods high in these will cook more quickly. Microwaves can only penetrate to a depth of 1½ - 2 inches(4-5cm) and as heat spreads through the food by conduction, just as in a traditional oven, the food cooks from the outside inwards.

CONVERSION CHARTS

WEIGHT MEASURES	
15 g	½ oz.
25 g	1 oz.
50 g	2 oz.
100 g	4 oz.
175 g	6 oz.
225 g	8 oz.
450 g	1 lb.

VOLUME MEASURES	
30 ml	1 fl.oz.
100 ml	3 fl.oz.
150 ml	5 fl.oz. (¼ pt)
300 ml	10 fl.oz. (½ pt)
600 ml	20 fl.oz. (1pt)

SPOON MEASURES	
1.25 ml	¼ tsp
2.5 ml	½ tsp
5 ml	1 tsp
15 ml	1 tbsp

FLUID MEASUREMENTS		
1 Cup	= 8 fl.oz.	= 240 ml
1 Pint	= 16 fl.oz. (UK 20 fl.oz.)	= 480 ml (UK 560 ml)
1 Quart	= 32 fl.oz. (UK 40 fl.oz.)	= 960 ml (UK 1120 ml)
1 Gallon	= 128 fl.oz. (UK 160 fl.oz.)	= 3840 ml (UK 4500 ml)

COOKING INSTRUCTIONS

Utensil Guide

Only use utensils that are suitable for use in microwave ovens.

To cook food in the microwave oven, the microwaves must be able to penetrate the food, without being reflected or absorbed by the dish used. Care must therefore be taken choosing the utensil. If the utensil is marked microwave-safe, you do not need to worry. The following table lists various of utensil and indicates whether and how they should be used in a microwave oven.

Utensil	Safe	Comments
Aluminum foil	▲	Can be used in small quantities to protect areas against overcooking. Arcing can occur if the foil is too close to the oven wall or if too much foil is used.
Crust plate	●	Do not preheat for more than 8minutes.
China and earthenware	●	Porcelain, pottery, glazed earthenware and bone china are usually suitable, unless deco-rated with a metal trim.
Disposable polyester cardboard dishes	●	Some frozen foods are packaged in these dishes.
Fast-food packaging • Polystyrene cups containers • Paper bags or newspaper • Recycled paper or metal trims	● × ×	Can be used to warm food. Overheating may cause the polystyrene to melt. May catch fire. May cause arcing.
Glassware • Oven-to-table ware • Fine glassware • Glass jars	● ● ●	Can be used, unless decorated with a metal trim. Can be used to warm foods or liquids. Delicate glass may break or crack if heated suddenly. Must remove the lid. Suitable for warming only.
Metal • Dishes • Freezer bag twist ties	× ×	May cause arcing or fire.
Paper • Plates, cups, napkins and Kitchen paper • Recycled paper	● ×	For short cooking times and warming. Also to absorb excess moisture. May cause arcing.
Plastic • Containers • Cling film • Freezer bags	● ● ▲	Particularly if heat-resistant thermoplastic. Some other plastics may warp or discolour at high temperatures. Do not use Melamine plastic. Can be used to retain moisture. Should not touch the food. Take care when removing the film as hot steam will escape. Only if boilable or oven-proof. Should not be airtight. Prick with a fork, if necessary.
Wax or grease-proof paper	●	Can be used to retain moisture and prevent spattering.

● : Recommended use

▲ : Limited Use

× : Not Recommended

COOKING TECHNIQUES

STANDING TIME

Dense foods e.g. meat, jacket potatoes and cakes, require standing time (inside or outside of the oven) after cooking, to allow heat to finish conducting to cook the center completely. Wrap meat joints and jacket potatoes in aluminium foil while standing. Meat joints need approx. 10-15 minutes, jacket potatoes 5 minutes. Other foods such as plated meal, vegetables, fish etc require 2-5 minutes standing. After defrosting food, standing time should also be allowed. If food is not cooked after standing time, return to the oven and cook for additional time.

MOISTURE CONTENT

Many fresh foods e.g. vegetables and fruit, vary in their moisture content throughout the season, particularly jacket potatoes. For this reason cooking times may have to be adjusted. Dry ingredients e.g. rice, pasta, can dry out during storage so cooking times may differ.

DENSITY

Porous airy foods heat more quickly than dense heavy foods.

CLING FILM

Cling film helps keep the food moist and the trapped steam assists in speeding up cooking times. Pierce before cooking to allow excess steam to escape. Always take care when removing cling film from a dish as the build-up of steam will be very hot.

SHAPE

Even shapes cook evenly. Food cooks better by microwave when in a round container rather than square.

SPACING

Foods cook more quickly and evenly if spaced apart. NEVER pile foods on top of each other.

STARTING TEMPERATURE

The colder the food, the longer it takes to heat

up. Food from a fridge takes longer to reheat than food at room temperature.

LIQUIDS

All liquids must be stirred before and during heating. Water especially must be stirred before and during heating, to avoid eruption. Do not heat liquids that have previously been boiled. DO NOT OVERHEAT.

TURNING & STIRRING

Some foods require stirring during cooking. Meat and poultry should be turned after half the cooking time.

ARRANGING

Individual foods e.g. chicken portions or chops, should be placed on a dish so that the thicker parts are towards the outside.

QUANTITY

Small quantities cook faster than large quantities, also small meals will reheat more quickly than large portions.

PIERCING

The skin or membrane on some foods will cause steam to build up during cooking. These foods must be pierced or a strip of skin should be peeled off before cooking to allow the steam to escape. Eggs, potatoes, apples, sausages etc, will all need to be pierced before cooking. DO NOT ATTEMPT TO BOIL EGGS IN THEIR SHELLS.

COVERING

Cover foods with microwave cling film or a lid. Cover fish, vegetables, casseroles, soups. Do not cover cakes, sauces, jacket potatoes or pastry items.

DEFROSTING GUIDE

Do not defrost covered meat. Covering might allow cooking to take place. Always remove outer wrap and tray. Use only containers that are microwave-safe.

Begin defrosting whole poultry breast-side-down. Begin defrosting roasts fat-side-down.

The shape of the package alters the defrosting time. Shallow rectangular shapes defrost more quickly than a deep block.

After 1/3 of the defrost time has elapsed, check the food. Toy may wish to turn over, break apart, rearrange or remove thawed portions of the food.

During defrost, the oven will prompt you to turn the over. At this point, open oven door and check the food. Follow the techniques listed below for optimum defrost results.

Then, close oven door, touch the START pad to complete defrosting.

When defrosted, food should be cool, but softened in all areas. If still slightly icy, return to microwave oven very briefly, or let stand a few minutes. After defrosting, allow food to stand 5-60 minutes if there are any icy areas.

Poultry and fish may be placed under running cool water until defrosted

Turn over : Roast, ribs, whole poultry, turkey breasts, hot dogs, sausages, steaks, or chops.

Rearrange : Break apart or separate steaks, chops, hamburger patties, ground meat, chicken or seafood pieces, chunks of meat such as stew beef.

Shield : Use small strips of aluminum foil to protect thin areas or edges of unevenly shaped foods such as chicken wings. To prevent arching, do not allow foil to come within 1-inch of oven walls or door.

Remove : To prevent cooking, thawed portions should be removed from the oven at this point. This may shorten defrost time for food weighing less than 3 lbs.(1350g).

DEFROSTING CHART (by time def.)

Item & Weight	Defrosting Time	Standing Time	Special Techniques
BEEF			
Minced beef 1 lb./450g	6-8 min.	15-20 min.	Break apart and remove thawed portions with fork.
Stew Meat 1 1/2 lbs./675g	7-9 min.	25-30 min.	Separate and rearrange once.
Patties 4(4oz./110g)	5-7 min.	15-20 min.	Turn over after half the time.
POULTRY			
Whole Chicken 2 1/2 lbs./1125g	12-15 min.	45-50 min.	Break side down. Turn over after half the time. Shield as needed.
Chicken Breasts 1 lbs./450g	6-8 min.	15-30 min.	Separate and rearrange once.
Fryer Chicken(cut up) 2 lbs./900g	10-12 min.	25-30 min	Separate and rearrange once.
Chicken Thights 1 1/2 lbs./675g	7-10 min.	15-30 min.	Separate and rearrange once.
FISH & SEAFOOD			
Whole Fish 1 lb./450g	4-5 min.	15-20 min.	Turn over after half the time. Shield as needed.
Fish Fillets 1 1/2 lb./675g	5-7 min.	15-20 min.	Separate and turn over once.
Shrimp 1/2 lb./225g	2-3 min.	15-20 min.	Separate and rearrange once.

* The times are approximate because freezer temperatures vary.

COOKING & REHEATING CHART

Cooking chart

Item	Power Level	Cooking Time Per lb./450g	Special Instruction
MEAT			<ul style="list-style-type: none"> - Chilled meat and poultry should be removed from the refrigerator at least 30 minutes before cooking. - Always let the meat and poultry stand, covered after cooking.
Beef joint - Rare	P-80	6-8 min.	
- Medium	P-80	7-9 min.	
- well done	P-80	9-11 min.	
POULTRY			
Whole chicken	P-HI	6-9 min.	
Portions chicken	P-80	4-6 min.	
Breast (boned)	P-80	5-7 min.	
FISH			<ul style="list-style-type: none"> - Brush a little oil or melted butter over the fish, or add 15~30ml(1-2 tbsp) lemon juice, wine, stock, milk or water. - Always let the fish stand, covered, after cooking
Fish Fillets	P-HI	3-5 min.	
Whole Mackerel, Cleaned and prepared	P-HI	3-5 min.	
Whole Trout, Cleaned & Prepared	P-HI	4-6 min.	
Salmon steaks	P-HI	4-6 min.	
<p>NOTE : The above times should be regarded only as a guide. Allow for difference in individual tastes and preferences. The times may vary due to the shape, cut, and composition of the food. Frozen meat, poultry and fish must be thoroughly thawed before cooking.</p>			

Reheating chart

- Baby food particularly needs to be checked carefully before serving to prevent burns.
- When heating pre-packaged ready cooked foods, always follow the pack instructions carefully.
- If you freeze foods which were bought from the fresh or chilled counters, remember that they should be thoroughly thawed before following the heating instructions on the packed. It's worth putting a note on them so that other members of the household will remember too.
- Remember metal ties and transfer food from foil containers before reheating.
- Chilled(refrigerated) food takes longer to reheat than food at room temperature (such as just-cooled food or food from the store cupboard).
- All foods should be reheated using full microwave power.

Item	Cooking time	Special Instructions
Baby food 128g jar	20-30 sec.	Empty into a small serving bowl. Stir well once or twice during heating. Before serving, check the temperature carefully.
Baby milk 100ml / 4fl.oz. 225ml / 8fl.oz.	20-30 sec. 40-50 sec.	Stir or shake well and pour into a sterilized bottle. Before serving, shake well and check the temperature carefully.
Sandwich roll or bun 1 roll	20-30 sec.	Wrap in paper towel and place on glass microwaveable rack. *Note : Do not use recycled paper towels.
Lasagna 1 serving (10 1/2 oz./300g)	4-6 min.	Place lasagna on microwaveable plate. Cover with plastic wrap and vent.
Casserole 1 cup 4 cups	1 1/2-3 min. 5-7 min.	Cook covered in microwaveable casserole. Stir once halfway through cooking.
Mashed potatoes 1 cup 4 cups	2-3 min. 6-8 min.	Cook covered in microwaveable casserole. Stir once halfway through cooking.
Baked beans 1 cup	2-3 min.	Cook covered in microwaveable casserole. Stir once halfway through cooking.
Ravioli or pasta in sauce 1 cup 4 cups	2-3 min. 6-9 min.	Cook covered in microwaveable casserole. Stir once halfway through cooking.

VEGETABLE CHART

Use a suitable glass pyrex bowl with lid. Add 30-45ml cold water(2-3 tbsp.) for every 250g unless another water quantity is recommended - see table. Cook covered for the minimum time - see table.

Continue cooking to get the result you prefer. Stir once during and once after cooking. Add salt, herbs or butter after cooking. Cover during a standing time of 3 minutes.

Hint : cut the fresh vegetables into even sized pieces. The smaller they are cut, the quicker they will cook.

All vegetables should be cooked using full microwave power.

Cooking Guide for fresh vegetables

Vegetables	Weight	Time	Comments
Broccoli	1/2 lb./250g 1 lb./500g	2-3 min 4-6 min	Prepare even sized florets. Arrange the stems to the centre.
Brussels sprouts	1/2 lb./250g	3-4 min	Add 60-75ml(5-6tbsp.) water.
Carrots	1/2 lb./250g	2-3 min	Cut carrots into even sized slices.
Cauliflower	1/2 lb./250g 1 lb./500g	2-3 min 4-6 min	Prepare even sized florets. Cut big florets into halves. Arrange stems to the centre.
Courgettes	1/2 lb./250g	2-3 min	Cut courgettes into slices. Add 30ml(2tbsp.) water or a knob of butter. Cook until just tender.
Egg plants	1/2 lb./250g	2-3 min	Cut egg plants into small slices and sprinkle with 1 tablespoon lemon juice.
Leeks	1/2 lb./250g	2-3 min	Cut leeks into thick slices.
Mushrooms	0.3 lb./125g 1/2 lb./250g	1-2 min 2-4 min	Prepare small whole or sliced mushrooms. Do not add any water. Sprinkle with lemon juice. Spice with salt and pepper. Drain before serving.
Onions	1/2 lb./250g	2-3 min	Cut onions into slices or halves. Add only 15ml(1tbsp.) water.
Pepper	1/2 lb./250g	2-4 min	Cut pepper into small slices.
Potatoes	1/2 lb./250g 1 lb./500g	4-6 min 7-9 min	Weigh the peeled potatoes and cut them into similar sized halves or quarters.
Turnip cabbage	1/2 lb./250g	4-6 min	Cut turnip cabbage into small cubes.

Cooking Guide for frozen vegetables

Vegetables	Weight	Time	Instructions
spinach	0.3 lb./125g	1-2 min	Add 15ml(1tbsp.) cold water.
broccoli	1/2 lb./250g	2 1/2-4 min	Add 30ml(2 tbsp.) cold water.
Peas	1/2 lb./250g	2 1/2-4 min	Add 15ml(1 tbsp.) cold water.
Green beans	1/2 lb./250g	3-5 min	Add 30ml(2tbsp.) cold water.
Mixed vegetables (carrots/peas/corn)	1/2 lb./250g	2 1/2-4 min	Add 15ml(1tbsp.) cold water.
Mixed vegetables (Chinese style)	1/2 lb./250g	3-5 min	Add 15ml(1 tbsp.) cold water.

CARE OF YOUR MICROWAVE OVEN

- 1 Turn the oven off before cleaning.
- 2 Keep the inside of the oven clean. When food spatters or spilled liquids adhere to **oven walls, plate tray, stirrer cover and inlet cover** wipe with a damp cloth. Mild detergent may be used if the oven gets very dirty. The use of harsh detergent or abrasives is not recommended.
- 3 The outside oven surface should be cleaned with soap and water, rinsed and dried with a soft cloth. To prevent damage to the operating parts inside the oven, water should not be allowed to seep into the ventilation openings.
- 4 If the Control Panel becomes wet, clean with a soft, dry cloth. Do not use harsh detergents or abrasives on Control Panel.
- 5 If steam accumulates inside or around the outside of the oven door, wipe with a soft cloth. This may occur when the microwave oven is operated under high humidity conditions and in no way indicates malfunction of the unit.

IMPORTANT CAUTIONS

1. Do not operate after removed food.
2. Do not operate the oven without **stirrer cover** in place.
3. Do not remove the **stirrer cover** and **plate tray**.

CARE AND CLEANING

Although your oven is provided with safety features, it is important to observe the following:

1. It is important not to defeat or tamper with safety interlocks.
2. Do not place any object between the oven front face and the door or allow residue to accumulate on sealing surfaces. Wipe the sealing area frequently with a mild detergent, rinse and dry. Never use abrasive powders or pads.
3. When opened, the door must not be subjected to strain, for example, a child hanging on an opened door or any load could cause the oven to fall forward to cause injury and also damage to the door. Do not operate the oven if it is damaged, until it has been repaired by a competent service technician. It is particularly important that the oven closes properly and that there is no damage to the:
 - i) Door(bent)
 - ii) Hinges and Hooks(broken or loosened)
 - iii) Door seals and sealing surfaces.
4. The oven should not be adjusted or repaired by anyone except a properly competent service technician.
5. The oven should be cleaned regularly and any food deposits removed;
6. Failure to maintain the oven in a clean condition could lead to deterioration of the surface that could adversely affect the life of the appliance and possibly result in a hazardous situation.

USE YOUR MICROWAVE OVEN SAFELY

General Use

Do not attempt to defeat or tamper with safety interlocks.

Do not place any object between the oven front frame and the door or allow residue to build up on sealing surfaces. Wipe with a mild detergent, rinse and dry. Never use abrasive powders or pads.

Do not subject the oven door to strain or weight such as a child hanging on an open door.

This could cause the oven to fall forward resulting in injury to you and damage to the oven.

Do not operate the oven if door seals or sealing surfaces are damaged; or if door is bent; or if hinges are loose or broken.

Do not operate the oven empty. This will damage the oven.

Do not attempt to dry clothes, newspapers or other materials in the oven. They may catch on fire.

Do not use recycled paper products as they may contain impurities which may cause sparks or fires.

Do not hit or strike the control panel with hard objects. This can damage the oven.

Food

Never use your microwave oven for home canning. The oven is not designed for proper home canning. Improperly canned food may spoil and be dangerous to consume.

Always use the minimum recipe cooking time. It is better to undercook rather than overcook foods.

Undercooked foods can be returned to the oven for more cooking. If food is overcooked, nothing can be done.

Heat small quantities of food or foods with low moisture carefully. These can quickly dry out, burn or catch on fire.

Do not heat eggs in the shell. Pressure may build up and eggs can explode.

Potatoes, apples, egg yolks and sausages are examples of food with non-porous skins.

These must be pierced before cooking to prevent bursting.

Do not attempt to deep fat fry in your microwave oven.

Always allow a standing time of at least 20 seconds after the oven has been switched off to allow the

temperature to even out, stir during heating, if necessary, and ALWAYS stir after heating. To prevent eruptive boiling and possible scalding, you should put a spoon or glass stick into the beverages and stir before, during and after heating.

Do not leave the oven unattended while popping corn.

Do not pop corn in a paper bag unless it is the commercially prepared Microwave Popcorn product. The kernels can overheat and ignite a brown paper bag.

Do not put packaged Microwave Popcorn bags directly on the oven tray. Place the package on a microwave safe glass or ceramic plate to avoid overheating and cracking the oven tray.

Do not exceed the Microwave Popcorn manufacturers suggested popping time.

Longer popping does not yield more popcorn but it can result in scorch, burn or fire. Remember, the Popcorn bag and tray can be too hot to handle.

Remove with caution and use pot holders.

ARCING

If you see arcing, open the door and correct the problem.

Arcing is the microwave term for sparks in the oven.

Arcing is caused by:

- Metal or foil touching the side of the oven.
- Foil not molded to food (upturned edges act like antennas).
- Metal, such as twist-ties, poultry pins, or gold rimmed dishes, in the microwave.
- Recycled paper towels containing small metal pieces being used in the microwave.

BEFORE YOU CALL FOR SERVICE

Refer to following checklist, you may prevent an unnecessary service call.

* The oven doesn't work;

1. Check that the power cord is securely plugged in.
2. Check that the door firmly closed.
3. Check that the cooking time is set.
4. Check for a blown circuit fuse or tripped main circuit breaker in your house.

* Sparking in the cavity;

1. Check that utensils are metal containers or dishes with metal trim.
2. Check that metal skewers touch the interior walls.

If there is still a problem, contact the service station.

A list of these stations is included in the oven.

DO NOT ATTEMPT TO SERVICE THE OVEN YOURSELF!

QUESTIONS AND ANSWERS

*** Q : I accidentally ran my microwave oven without any food in it. Is it damaged?**

A : Running the oven empty for a short time will not damage the oven. However, it is not recommended.

*** Q : Can the oven be used with the plate tray removed?**

A : No. Plate tray must always be used in the oven before cooking

*** Q : Can I open the door when the oven is operating?**

A : The door can be opened anytime during the cooking operation. Then microwave energy will be instantly switched off and the time setting will maintain until the door is closed.

*** Q : Why do I have moisture in my microwave oven after cooking?**

A : The moisture on the side of your microwave oven is normal. It is caused by steam from cooking food hitting the cool oven surface.

*** Q : Does microwave energy pass through the viewing screen in the door?**

A : No. The metal screen bounces back the energy to the oven cavity. The holes are made to allow light to pass through. They do not let microwave energy pass through.

*** Q : Why do eggs sometimes pop?**

A : When baking or poaching eggs, the yolk may pop due to steam build-up inside the yolk membrane. To prevent this, simply pierce the yolk with a toothpick before cooking. Never cook eggs without piercing their shells.

*** Q : Why this standing time recommended after the cooking operation has been completed?**

A : Standing time is very important. With microwave cooking, the heat is in the food, not in the oven. Many foods build up enough internal heat to allow the cooking process to continue, even after the food is removed from the oven. Standing time for joints of meat, large vegetables and cakes is to allow the inside to cook completely, without overcooking the outside.

*** Q : What does "standing time" mean?**

A : "Standing time" means that food should be removed from the oven and covered for additional time to allow it to finish cooking. This frees the oven for other cooking.

*** Q : Why does my oven not always cook as fast as the microwave cooking guide says?**

A : Check your cooking guide again, to make sure you've followed directions exactly ; and to see what might cause variations in cooking time. Cooking guide times and heat settings are suggestions, to help prevent over-cooking... the most common problem in getting used to a microwave oven. Variations in the size, shape and weights and dimensions could require longer cooking time. Use your own judgement along with the cooking guide suggestions to check whether the food has been properly cooked just as you would do with a conventional cooker.

*** Q : Will the microwave oven be damaged if it operates while empty?**

A : Yes. Never run it empty.

*** Q : Can I pop popcorn in my microwave oven? How do I get the best results?**

A : Yes. Pop packaged microwave popcorn following manufacture's guidelines. Do not use regular paper bags. Use the "listening test" by stopping the oven as soon as the popping slows to a "pop" every 1 or 2 seconds. Do not repop unpopped kernels. Do not pop popcorn in glass cookware.

RADIANCE

4184 Conant St.,
Long Beach, CA 90808
TEL: 1-310-900-1000
FAX: 1-310-900-1066
TOLL FREE: 800-627-0032
(USA & CANADA)
<http://www.turboairinc.com>

LIMITED WARRANTY

WARRANTY CLAIM:

German Knife / Radiance warrants that the equipment, as supplied from the factory to the end-user, is free from defects in materials and workmanship. Should any part be found defective resulting from normal use within the defined warranty period, German Knife / Radiance will gladly dispatch an authorized service agency to repair and/or replace necessary parts under the following conditions.

Repairs under this warranty are to be performed by a German Knife / Radiance authorized service agency only. German Knife / Radiance will not be responsible for service parts and labor charges performed by non-authorized service companies. All claims should include the model number, serial number, proof of purchase, date of installation, and all pertinent information supporting the alleged defect.

PRODUCTS UNDER WARRANTY:

One Year Warranty:

- Radiance Medium Duty Microwaves- ER/MR series (TMW-1100ER, TMW-1100MR)
- Radiance Ranges & Countertop cooking series
(All TAR-, TARG-, TAHP-, TARB-, TAMG-, TATG-, TASP-, TAWR-)
- Radiance Cheesemelters, Salamanders, Steam Tables, Hand Wrappers, and Food Warmers
(All TACM-, TASM-, RST-, RHW-, RFW-)
- German Knife Light Duty Slicer- LD series (GS-10LD, GS-12LD)

Two Year Warranty:

- German Knife Heavy Duty Meat Slicer- Automatic & Manual (GS-12A, GS-12M, GS-13A, GS-13M)
- German Knife Meat Grinder (All GG-)
- German Knife Band Saw (All GBS-)

Three Year Warranty:

- Radiance Heavy Duty Microwaves- HD Series (TMW-1200HD, TMW-1800HD)

Any part covered under this warranty that is found by German Knife / Radiance to have been defective within the above time period is limited to the repair or replacement, including labor charges, of defective parts or assemblies. The labor charges shall include standard straight time labor charges only and reasonable travel time as determined by German Knife / Radiance.

WHAT IS NOT COVERED BY THIS WARRANTY:

German Knife / Radiance's sole obligation under this warranty is limited to either repair or replacement of parts, subject to the additional limitations below. This warranty neither assumes nor authorizes any person to assume obligations other than those expressly covered by this warranty.

- Equipment failure resulting from improper installation will not be honored under warranty. Examples are wrong utility connection and improper utility supply problems.
- Equipment that has not been maintained accordingly. Examples are calibration of controls, adjustment to pilots and burners, and damage from improper cleaning.
- Equipment that has not been used in an appropriate manner, alteration, neglect, abuse, misuse, accident, damage during transit or installation, fire, food, acts of God.
- Warranty is not transferrable and only applies in favor of the original purchaser.
- Equipment failure resulting from electrical power failure, use of extension cords, low voltage, and voltage drops to the unit.

These warranties are exclusive and in lieu of all other warranties, including implied warranty and merchantability or fitness for a particular purpose. No consequential damages. German Knife / Radiance is not responsible for economic loss, profit loss or special, indirect, or consequential damages. There are no warranties which extend beyond the description on the face hereof.

Outside the U.S., this warranty does not apply to, and German Knife / Radiance is not responsible for, any warranty claims made on products sold or used outside the continent of the United States.